

Magnetic proximity switch Series CST-CSV

- Reed
- Hall effect

The magnetic proximity switches CST/CSV detect the position of the cylinder magnetic piston. When the internal contact is actuated by a magnetic field, the sensors complete an electrical circuit and provide an output signal to actuate directly a solenoid valve or a PLC. A yellow LED diode shows when the internal magnetic contact is closed. The Reed switch has a "mechanical switching" element and is suitable for voltages, AC and DC, up to 110V, and has a shorter operational life than Hall effect type. The Hall effect sensor has a longer operational life but as it is constructed from semi conductor material is only suitable for DC voltages up to 30V. The 2 types of proximity switches are both impregnated in a sealed isolating cover, therefore externally they are the same. These sensors are designed to fit into the grooves provided in the profile barrel of "compact" and "rodless" cylinders or on the surface of roundline and tie rod cylinders by using mounting bands or brackets.



The reed version with 3 wires allows the connection of several sensors in series, as there is no voltage drop between the supply and the load (see connecting scheme). The voltage drop is 2.5V for the 2 wire version and 1V for Hall effect sensors. For electrical connections see schemes beside. For maximum loads see diagrams of fig.1 and 2.

- ▶ Designed to fit into the cylinder profile barrel
- ▶ 2 models (CST-CSV) are suitable for all Camozzi's cylinder range
- ▶ With or without M8 connector

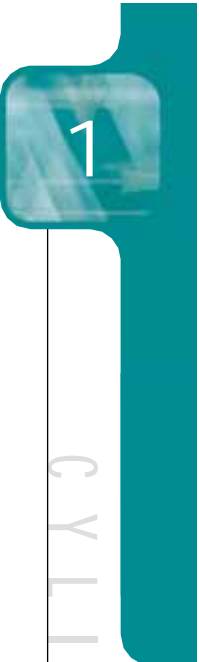

CYLINDERS

GENERAL DATA			
Mod.	CST-220 CSV-220	CST-232 CSV-232	CST-332 CSV-332
	CST-250 CSV-250	CST-262 CSV-262	CST-362 CSV-362
Operation	Reed contact		Hall effect
Output	--		PNP
Voltage	10-110 V AC/DC	5-30 V AC/DC	10-27 V DC
Protection	IP 67		
Materials	Plastic body encapsulating epoxy resin, PVC, PUR sheathed cable		
Mounting	Directly into the groove, or by means of adapters (only CST)		
Signalling	By means of yellow diode Led		
Electrical connection	cable 2x0,14 (2m)	cable 3x0,14 (2m)	
	connector M8 (0,3 m)	connector M8 (0,3 m)	
Max. current	250 mA inductive		
Max. load	8 W, 10 VA		6 W
Protection	none	against polarity reversing	against polarity reversing against reverse spikes
Switching time	<1,8 ms		<1 ms
Operat. temperature	-10°C ÷ 80°C		
Type of contact	N.O.		
Electrical duration	10 ⁷ cycles		10 ⁹ cycles

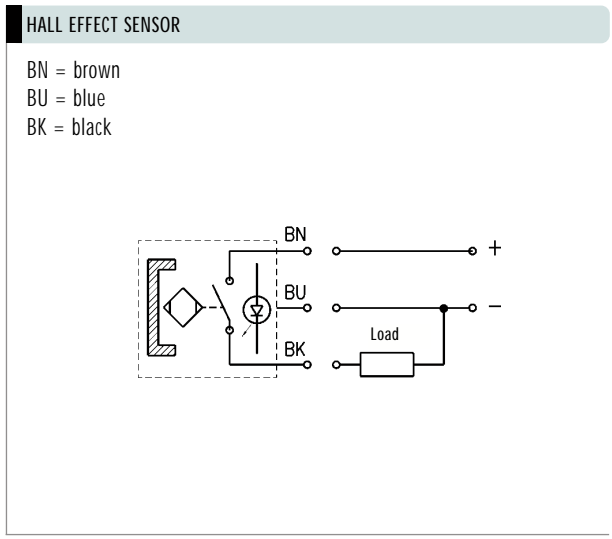
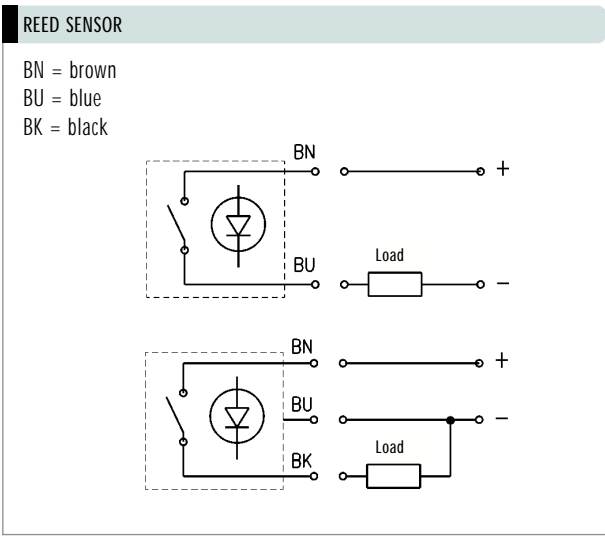
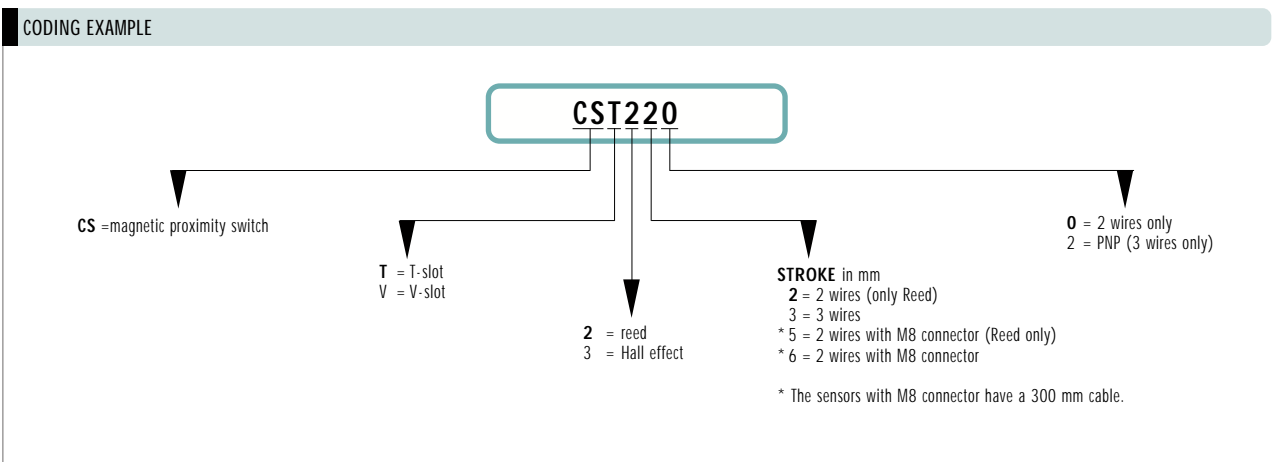

The company reserves the right to vary models and dimensions without notice. These products are designed for industrial applications and are not suitable for sale to the general public.

CONNECTING SCHEMES IN SERIES

The reed version with 3 wires allows the connection of several sensors in series, as there is no voltage drop between the supply and the load (see connecting scheme). This voltage drop is 2.5V for the 2 wire version and 1V for Hall effect sensors.

BN = brown
 BU = blue
 BK = black

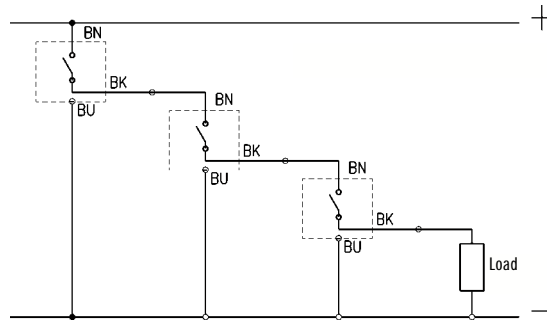

Magnetic proximity switch Series CST



Mod.

- CST - 220
- CSV - 220
- CST - 232
- CSV - 232
- CST - 332
- CSV - 332

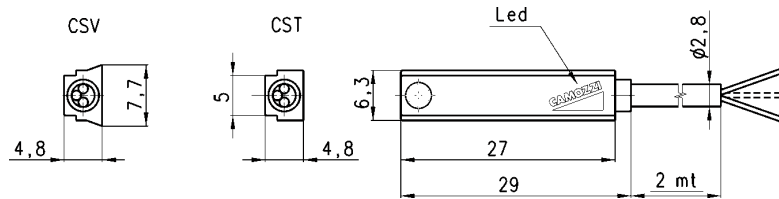

Connector Series CST



Mod.

- CST - 250
- CSV - 250
- CST - 262
- CSV - 262
- CST - 362
- CSV - 362

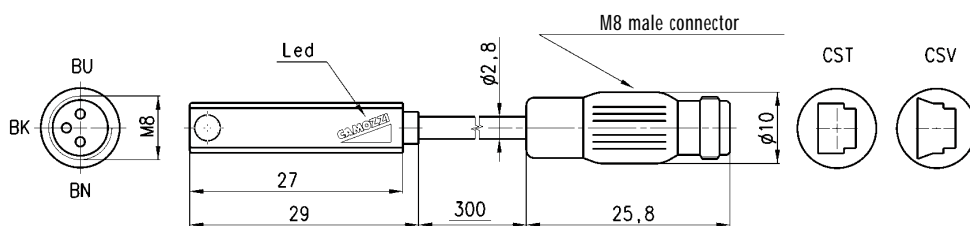

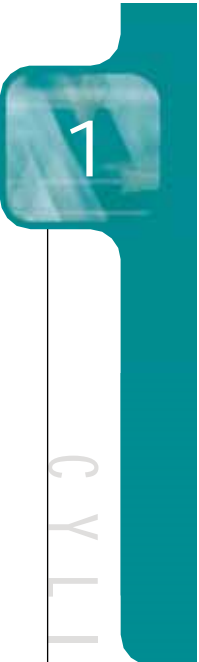

CYLINDERS

Connector Mod. CS-5

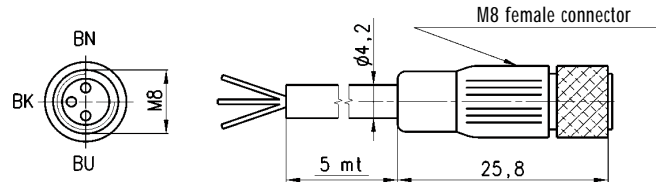

Mod.
CS-5

Useful information for correct use of the magnetic sensors

The magnetic sensors consist of a reed switch which is enclosed in a glass bulb containing a rarified gas. The contacts, which are made of magnetic material (nickel-iron), are flexible and are coated, at the contact points with a high quality non-arcing material. Switching is effected by means of a suitable magnetic field and actuation is achieved by means of the permanent magnet inside the piston. The two sensors are of the normally open type and, therefore, when they are subject to the effect of the magnetic field, they close the circuit. The operating field of the sensors with respect to the magnetic piston is shown in Figure 2. The dimension b indicates the amplitude of the magnetic field or switching field during which the circuit is closed. The value H represents the operational hysteresis of the sensor with respect to the form and amplitude of the magnetic field. The operating field, as a result of hysteresis, is displaced by the dimension H in the opposite direction to movement of the piston. The values b and H are shown in the table and are classified according to bore. The maximum speed permitted for each cylinder is a function of the value b and the response time of the various components connected after the sensor.

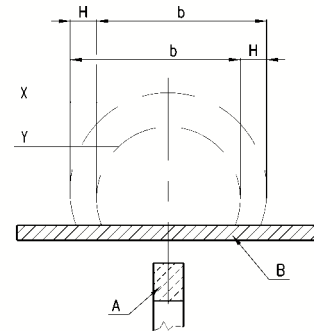

Maximum operating speed

The maximum speed for a cylinders guided by magnetic sensors is calculated as follows:

$$\frac{b}{t} = \text{speed}$$

where:

b = contact stroke in mm (see table)

t = total reaction time in milli seconds of electric control components connected after the sensor

Speed = maximum speed in m/second

THESE VALUES ARE VALID WHEN THE SENSOR IS MOUNTED IN CONTACT WITH THE CYLINDER'S TUBE.

Series	cylinder bore	b contact stroke (mm)	H hysteresis (mm)	Series	cylinder bore	b contact stroke (mm)	H hysteresis (mm)	Series	alesaggi cilindri	b contact stroke (mm)	H hysteresis (mm)
QP	12	5,2	2,1	27	50	14,5	1,3	41	32	10,3	1,6
QP	16	8,8	2,9	27	63	16,2	1	41	40	9,8	2
QP	20	14	1,2	31	12	9,4	0,8	41	50	12,8	1,9
QP	25	14,6	1,4	31	16	8,9	1,2	41	63	13	2,3
QP	32	16	1,5	31	20	8	1,5	41	80	15,1	2,5
QP	40	15,5	1,1	31	25	11,7	1,5	41	100	15,8	2,2
QP	50	18,2	1,3	31	32	9,9	1,5	42	32	12,8	1,8
QP	63	19,3	1,5	31	40	12,5	2	42	40	13	1,8
QP	80	19,6	1,9	31	50	15	2	42	50	14,1	1,7
QP	100	22	1,5	31	63	15,2	2,1	42	63	16,2	1,5
24-25	12	9,5	1,3	31	80	14,8	2,7	50	16	8,5	1,5
24-25	16	10,5	1,5	31	100	21,5	3,5	50	25	13,5	2
24-25	20	11,3	1,1	40	32	8,2	2	50	32	19	1,7
24-25	25	13	1,2	40	40	7	2,5	50	40	17,3	1,7
27	20	10,5	1	40	50	11,1	1,8	50	50	29,5	3
27	25	8,5	1,5	40	63	12,4	1,7	50	63	32	2,2
27	32	10	1,3	40	80	14,4	1,7	50	80	31	3,5
27	40	12	1,3	40	100	17,4	1,7				

Maximum load of magnetic proximity switch (Reed)

Mod.
CST/CSV-232
CST/CSV-262

- Inductive / capacitive loads
8W DC - 10VA AC;
max. current = 250 mA;
- Resistive loads
10W/VA, 500mA AC/DC

Fig. 1

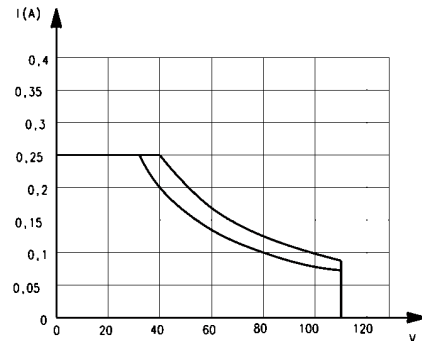

Mod.
CST/CSV-220
CST/CSV-250

- Inductive / capacitive loads
8W DC - 10VA AC
The effective load in amps is a function of the operating voltage indicated in fig. 1
- Resistive loads
10W/VA DC/AC, 250 mA
The effective load in amps is a function of the operating voltage indicated in fig. 2

Fig. 2

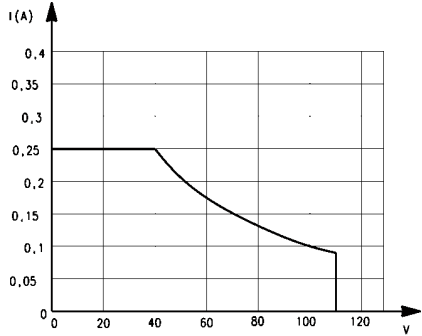

Electric circuit with protection against the voltage spikes.

There is no protection on the Reed sensors on the inductive load, therefore it is advisable to use an electric circuit with protection against the voltage spikes. See the figure beside for 3 examples.

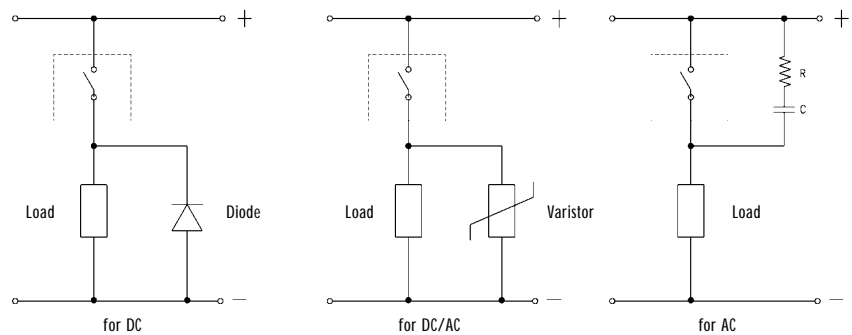

Mounting bands for sensors Series CST

Mod.	
S-CST-05	for cylinders ø16-20-25 Series 24-25-27
S-CST-06	for cylinders ø32 Series 27-42
S-CST-07	for cylinders ø40 Series 27-42
S-CST-08	for cylinders ø50 Series 27-42
S-CST-09	for cylinders ø63 Series 27-42

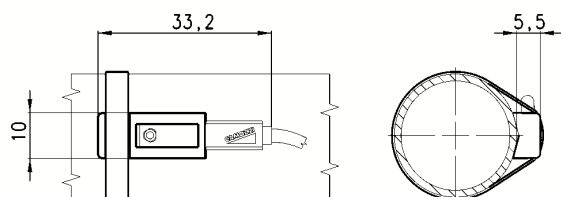

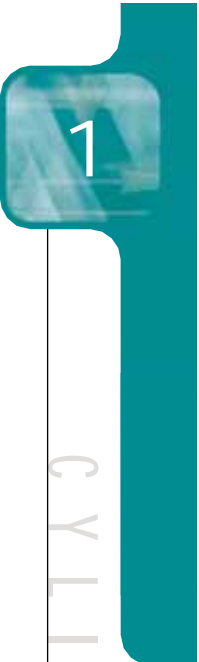

CYLINDERS

Adaptors for sensors Series CST

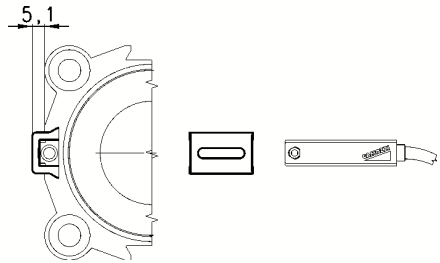

Mod.	
S-CST-01	for cylinders $\varnothing 20 \div 100$ Series QP-QPR
	for cylinders $\varnothing 32 \div 80$ Series 50

Profile barrel mounting brackets Series CST

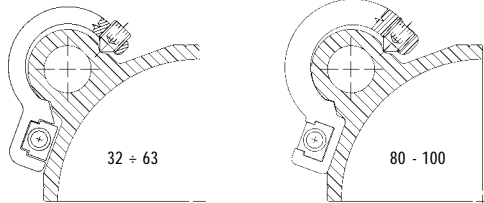

Mod.	
S-CST-16	for cylinders $\varnothing 32-63$ Series 29-41
S-CST-17	for cylinders $\varnothing 80-100$ Series 29-41

Tie rod mounting brackets Series CST

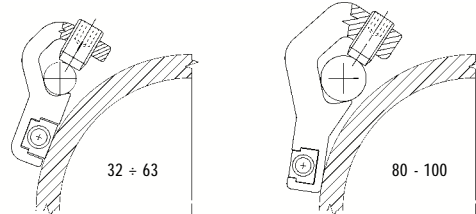

Mod.	
S-CST-25	for cylinders $\varnothing 32-63$ Series 40
S-CST-26	for cylinders $\varnothing 80-100$ Series 40

Sensor Series CSV

CST sensor must be assembled directly into the groove:
for cylinders $\varnothing 16 \div 25$ Series 50
for cylinders $\varnothing 12 \div 16$ Series QP-QPR.

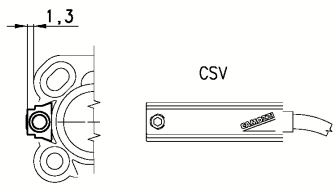

Sensor Series CST

CST sensor must be assembled directly into the groove:
for cylinders Series 31-31R
for cylinders Series QC.

